

Chippewa School District
Board of Education Regular Meeting
Chippewa Jr/Sr High School Auditorium
Monday, June 13, 2022 @ 6:00 PM

BOARD MEETING MINUTES

I. OPENING

- A. Call to Order :: Moment of Silence :: Pledge of Allegiance
- B. Present: Mr. DeAngelis, Mrs. Fenn, Mr. Golub, Mr. Hershberger, Mr. Schafrath

RESOLUTION 043-22

- C. Upon consideration to approve the minutes from the May 9, 2022 Regular Meeting.
Motion to approve by Fenn and 2nd by Schafrath
Roll Call: DeAngelis yes, Fenn yes, Golub yes, Hershberger yes, Schafrath yes **CARRIED**

II. STUDENT RECOGNITION /STAFF RECOGNITION /INTRODUCTION OF GUESTS

- A. Student Recognition
 - Andrew Yeager – 2nd round of the National Spelling Bee in Washington D.C.
 - Wayne County Art Exhibit
 - Watercolor Award: Honorable Mention – Blake Nicholas and Chandler Prior-Schwartz
 - Oil/Acrylic Award: 2nd Place – Addison Good
 - Photography Award: 1st Place – Addison Good
 - 2nd Place – Meredith Wilson
 - Honorable Mention – Addison Good
 - Crafts Award: 1st Place – Caroline Dobbins
 - Stained Glass: 1st Place – Marissa Storad

 - Kennedy Good placed 20th out of 200 finalists, at the State Power of the Pen tournament at Otterbein University in May.

 - William Browning – Gold Medal in Trap Shooting at the Jr. Olympics.
- B. Needle Mover – Beth Ogg

III. PUBLIC PARTICIPATION

- 1 Public Participant regarding school safety concerns

IV. SUPERINTENDENT’S REPORT

- A. Police Chief Tester – Discussion on School Safety and active shooter protocol
- B. Suspicious Emails –
 - 1. We do not ask for personal information via email.
 - 2. Final Forms is the secure platform used by Chippewa Schools to ask for personal information for students that attend our schools.

V. TREASURER'S UPDATE & AGENDA ITEMS

A. Treasurer's Comments

June is the final month of Fiscal Year 2022

At the June 29th Board Meeting, action needs to be taken on final appropriations for Fiscal Year 2022; temporary or permanent appropriations for Fiscal Year 2023; and fund to fund transfers or advances in closing out the Fiscal Year 2022.

RESOLUTION 044-22

B. Action Items

- a) Upon consideration to approve the May 2022 financial report (copy on file at the Doylestown Public Library)
- b) Upon consideration to approve the Administrative Salary schedules for certified and non-certified staff per exhibit A.
- c) Upon consideration to consider the approval of the "then and now" payment for invoice/statement dated 5/31/2022 in the amount of \$14,139.04 payable to Lyden Oil Company for bus fuel – PO# 22001039
- d) Upon consideration to approve the payment of \$46,346.54 per board approved contract to ANAZAO Community Partners (8/9/2021 Board Meeting **RESOLUTION 083-21**)

Motion to approve by Fenn and 2nd by Golub

Roll Call: DeAngelis yes, Fenn yes, Golub yes, Hershberger yes, Schafrath yes **CARRIED**

VI. SUPERINTENDENT'S AGENDA

RESOLUTION 045-22

- a) Upon consideration to approve the hiring of Angela Deiotte with a Two-Year Contract as the Hazel Harvey principal as of August 1st, 2022 and ending July 31st, 2024 - Step 4, per administrative pay scale

Motion to approve by Fenn and 2nd by Schafrath

Roll Call: DeAngelis yes, Fenn yes, Golub yes, Hershberger yes, Schafrath yes **CARRIED**

RESOLUTION 046-22

- b) Upon consideration to approve the hiring of Kyle Metzger as an Intervention Specialist – Step 7, MA per teacher's salary schedule

Motion to approve by Fenn and 2nd by Golub

Roll Call: DeAngelis yes, Fenn yes, Golub yes, Hershberger yes, Schafrath yes **CARRIED**

RESOLUTION 047-22

- c) Upon consideration to approve the hiring of Ian Leja as an Intervention Specialist –

Step 0, MA per teacher's salary schedule

Motion to approve by Golub and 2nd by Schafrath

Roll Call: DeAngelis yes, Fenn yes, Golub yes, Hershberger yes, Schafrath yes **CARRIED**

RESOLUTION 048-22

- d) Upon consideration to approve the hiring of Emily Ramseyer as Jr/Sr HS Math Teacher – Step 0, BS + 150 per teacher's salary schedule. (amended per June 29, 2022 Board Meeting)

Motion to approve by Fenn and 2nd by Golub

Roll Call: DeAngelis yes, Fenn yes, Golub yes, Hershberger yes, Schafrath yes **CARRIED**

RESOLUTION 049-22

- e) Upon consideration to approve the hiring of Tiffany Schreck, RN, as Part-Time School Nurse – \$23hr as needed (25 hours per week)

Motion to approve by Fenn and 2nd by Schafrath

Roll Call: DeAngelis yes, Fenn yes, Golub yes, Hershberger yes, Schafrath yes **CARRIED**

RESOLUTION 050-22

- f) Upon consideration to approve the hiring of Brook Gill as Title One Tutor at Hazel Harvey – per tutor scale

Motion to approve by Golub and 2nd by Schafrath

Roll Call: DeAngelis yes, Fenn yes, Golub yes, Hershberger yes, Schafrath yes **CARRIED**

VII. SUPERINTENDENT'S CONSENT AGENDA

RESOLUTION 051-22

- A) Upon consideration to approve to purchase walk-in freezer for Hazel Harvey kitchen – Cost \$28,075.00, P.O.#22001038 (paid through food service fund – 006)
- B) Upon consideration to approve to purchase sink/grease trap for Hazel Harvey Kitchen – Cost \$10,620.00, P.O.#22001037 (paid through food service fund – 006)
- C) Upon consideration to approve the resignation of Crystal Robinson, Intervention Specialist at Chippewa Intermediate School.
- D) Upon consideration to approve to sell, scrap and/or discard appliances, fixtures and equipment per exhibit F.
- E) Upon consideration to approve the Auxiliary Service 1-year contracts for Saints Peter & Paul School for the following (funded with Auxiliary, Title and IDEA-B funds).

Stephanie Casto	Auxiliary Clerk	1hr/3 days per week	\$15.14/hour
Mary Pawlicki	Diagnostic School Nurse	13hrs per month	\$15.00/hour
Charlotte Lisle	Speech-Lang Pathologist	3hrs/day-1 day/week	\$27.58/hour
Pam Douglas	Speech-Lang Pathologist	3hrs/day-1 day/week	\$27.58/hour
Briana Whited	Intervention Specialist	8-10hrs/week Step 7 BS	\$35.04/hour

- F) Upon consideration to approve the hiring of Brenda Dumont as a Substitute Kitchen Aide.
- G) Upon consideration to approve to purchase new school bus – Cost \$105,542.00 PO# 2200966 (funded by state grant of \$45,000.00 balance through PI fund- 003)
- H) Upon consideration to approve the voluntary transfer of Kathi Galehouse to Para-Professional Instructional Aid – 7.5hrs Step 2
- I) Upon consideration to approve the following supplemental contracts for the 2022-2023 school year.

<u>Supplemental Name</u>	<u>Person</u>	<u>Percent</u>
Junior Class Advisor ½	Ruth Coney	2.375%
Marching Band Director	Christopher Jones	16.00%
Assistant Band Director	Jason Raffle	3.75%
Color Guard Director	Hannah Hughes	3.50%
HS Assistant Play Director	Makenzie Thacker	4.50%
Theater Consultant Tech HS	Alexa McCleaster	\$250 *per performance
Theater Consultant Tech MS	Alexa McCleaster	\$150 *per performance
Theater Volunteer	Matthew Filo	0%
Theater Volunteer	Adrienne Jones	0%
Girls Soccer JV Coach	Beth Lewis	7.25%
Girls Soccer Assistant Coach	Mary Kay Hajek	2.75%
Girls Soccer Volunteer Asst. Coach	Joan West	0%
Girls Soccer Volunteer Asst. Coach	Emily Constanzo	0%
Boys Soccer Assistant Coach	Joe Henthorn	2.75%

Motion to approve by Fenn and 2nd by Golub

Roll Call: DeAngelis yes, Fenn yes, Golub yes, Hershberger yes, Schafrath yes **CARRIED**

J) ITEMS OF DISCUSSION

- A. Board - Income Tax Renewal Discussion (TD)
- B. Legislative Update
- C. Hazel Harvey Roof (KS) (Facility Committee update)

K) NEW BUSINESS

RESOLUTION 052-22

- A. Upon consideration for APPROVAL FOR RENEWAL OF SCHOOL DISTRICT INCOME TAX
It is recommended that the Board of Education approve the attached resolution requesting certification of alternate tax rates (Exhibit I) for the renewal of a 5 year School District Income Tax levy due to expire on December 31, 2022.

Motion to approve by Golub and 2nd by Fenn

Roll Call: DeAngelis yes, Fenn yes, Golub yes, Hershberger yes, Schafrath yes **CARRIED**

VIII. EXECUTIVE SESSION

WHEREAS, a public board of education may hold an executive session only after a majority quorum of this board determines by a roll call vote to hold such a session and only at a regular or special meeting for the purpose of the consideration of any of the following matters:

- A. To consider one or more, as applicable, of the check marked items with respect to a public employee or official:
 - 1. Appointment
 - 2. Employment
 - 3. Dismissal
 - 4. Discipline
 - 5. Promotion
 - 6. Demotion
 - 7. Compensation
 - 8. Investigation of charges/complaints (unless public hearing requested)
- B. To consider the purchase of property for the public purposes or for the sale of property at competitive bidding.
- C. Conferences with an attorney for the public body concerning disputes involving the public body that are the subject of pending or imminent court action.
- D. Preparing for, conducting or reviewing negotiations or bargaining sessions with public employees concerning their compensation or other terms and conditions of their employment
- E. Matters to be kept confidential by federal law or rules or state statutes ✓
- F. Specialized details of security arrangements where disclosure of the matters discussed might reveal information that could be used for the purpose of committing or avoiding prosecution for a violation of the law

NOW, THEREFORE BE IT RESOLVED, that the Chippewa Board of Education, by a majority of the quorum present at this meeting, does hereby declare its intention to hold an executive session on **Item E** as listed above.

TIME 7:08 P.M.

Motion to approve by Fenn and 2nd by Schafrath

Roll Call: DeAngelis yes, Fenn yes, Golub yes, Hershberger yes, Schafrath yes **CARRIED**

RECONVENED AT 7:45 P.M.

VIII. ADJOURNMENT

Motion to adjourn at 7:46 P.M. by Fenn and 2nd by Hershberger

Roll Call: DeAngelis yes, Fenn yes, Golub yes, Hershberger yes, Schafrath yes **CARRIED**

NOTE: *The next Regular Meeting will be held on June 29, 2022 beginning at 6:00 PM.*

EX. A
pt. 1

ADMINISTRATIVE SALARY SCHEDULE for Certified Admin Staff

For Fiscal Year 2023 - Certified

NOTE: Annually change formula in row 13 to match employee longevity as of Aug 1 of new year

Longevity @ Aug 1 2023

	5	7	0	4	5	0	11	13
FY-2023 PROPOSED SALARY	\$ 76,514.21	\$ 66,634.05	\$ 72,477.91	\$ 79,743.25	\$ 84,586.81	\$ 72,477.91	\$ 87,412.22	\$ 106,856.66
FY22 Salary-->	67,196.84	61,026.58	71,183.24	77,162.84	80,351.96	86,730.20		105,535.61
CURRENT								
contract days	220	186	220	220	220	220	220	224
days +/- 184	36	2	36	36	36	36	36	40
	7,897.11	438.73	7,897.11	7,897.11	7,897.11	7,897.11	7,897.11	8,774.57
Base Days 184	76,514.21	66,634.05	72,477.91	79,743.25	84,586.81	72,477.91	87,412.22	106,856.66

Base per diem = \$ 219.36

21-22 Base= \$ 40,363.00

<-----Base to be adjusted every 4th year. Next change to be for FY-2027

Longevity	0.02		0.03		Student	Athletic	SRHS Assoc	Hazel Harvey		Literacy	SRHS Principal
	Longevity Calculated	Longevity Calculated	Longevity Calculated	Longevity Calculated	Service Dir	School Psych Director	Principal	CIS Principal	Principal	Coordinator	
0	0.00	0.00	1.4	1.6	1.5	1.6	1.7	1.8	1.6	1.75	2.1
1	0.02	0.03	56,508.20	64,580.80	60,544.50	64,580.80	68,617.10	72,653.40	64,580.80	70,635.25	84,762.30
2	0.04	0.06	57,315.46	65,388.06	61,351.76	65,388.06	69,424.36	73,460.66	65,388.06	71,442.51	85,973.19
3	0.06	0.09	58,122.72	66,195.32	62,159.02	66,195.32	70,231.62	74,267.92	66,195.32	72,249.77	87,184.08
4	0.08	0.12	58,929.98	67,002.58	62,966.28	67,002.58	71,038.88	75,075.18	67,002.58	73,057.03	88,394.97
5	0.10	0.15	59,737.24	67,809.84	63,773.54	67,809.84	71,846.14	75,882.44	67,809.84	73,864.29	89,605.86
6	0.12	0.18	60,544.50	68,617.10	64,580.80	68,617.10	72,653.40	76,689.70	68,617.10	74,671.55	90,816.75
7	0.14	0.21	61,351.76	69,424.36	65,388.06	69,424.36	73,460.66	77,496.96	69,424.36	75,478.81	92,027.64
8	0.16	0.24	62,159.02	70,231.62	66,195.32	70,231.62	74,267.92	78,304.22	70,231.62	76,286.07	93,238.53
9	0.18	0.27	62,966.28	71,038.88	67,002.58	71,038.88	75,075.18	79,111.48	71,038.88	77,093.33	94,449.42
10	0.20	0.30	63,773.54	71,846.14	67,809.84	71,846.14	75,882.44	79,918.74	71,846.14	77,900.59	95,660.31
11	0.22	0.31	64,580.80	72,653.40	68,617.10	72,653.40	76,689.70	80,726.00	72,653.40	78,707.85	96,871.20
12	0.24	0.32	65,388.06	73,460.66	69,424.36	73,460.66	77,496.96	81,533.26	73,460.66	79,515.11	97,274.83
13	0.26	0.33	66,195.32	74,267.92	70,231.62	74,267.92	78,304.22	82,340.52	74,267.92	80,322.37	97,678.46
14	0.28	0.34	67,002.58	75,075.18	71,038.88	75,075.18	79,111.48	83,147.78	75,075.18	81,129.63	98,082.09
15	0.30	0.35	67,809.84	75,882.44	71,846.14	75,882.44	79,918.74	83,955.04	75,882.44	81,936.89	98,485.72
16	0.32	0.36	68,617.10	76,689.70	72,653.40	76,689.70	80,726.00	84,762.30	76,689.70	82,744.15	98,889.35
17	0.34	0.37	69,424.36	77,496.96	73,460.66	77,496.96	81,533.26	85,569.56	77,496.96	83,551.41	99,292.98
18	0.36	0.38	70,231.62	78,304.22	74,267.92	78,304.22	82,340.52	86,376.82	78,304.22	84,358.67	99,696.61
19	0.38	0.38	71,038.88	79,111.48	75,075.18	79,111.48	83,147.78	87,184.08	79,111.48	85,165.93	100,100.24
20	0.38	0.38	71,846.14	79,918.74	75,882.44	79,918.74	83,955.04	87,991.34	79,918.74	85,973.19	100,100.24
21	0.40	0.38	72,653.40	80,726.00	76,689.70	80,726.00	84,762.30	88,798.60	80,726.00	86,780.45	100,100.24
22	0.40	0.38	72,653.40	80,726.00	76,689.70	80,726.00	84,762.30	88,798.60	80,726.00	86,780.45	100,100.24
23	0.40	0.38	72,653.40	80,726.00	76,689.70	80,726.00	84,762.30	88,798.60	80,726.00	86,780.45	100,100.24
24	0.40	0.38	72,653.40	80,726.00	76,689.70	80,726.00	84,762.30	88,798.60	80,726.00	86,780.45	100,100.24
25	0.40	0.38	72,653.40	80,726.00	76,689.70	80,726.00	84,762.30	88,798.60	80,726.00	86,780.45	100,100.24
26	0.40	0.38	72,653.40	80,726.00	76,689.70	80,726.00	84,762.30	88,798.60	80,726.00	86,780.45	100,100.24
27	0.40	0.38	72,653.40	80,726.00	76,689.70	80,726.00	84,762.30	88,798.60	80,726.00	86,780.45	100,100.24
28	0.40	0.38	72,653.40	80,726.00	76,689.70	80,726.00	84,762.30	88,798.60	80,726.00	86,780.45	100,100.24
29	0.40	0.38	72,653.40	80,726.00	76,689.70	80,726.00	84,762.30	88,798.60	80,726.00	86,780.45	100,100.24
30	0.40	0.38	72,653.40	80,726.00	76,689.70	80,726.00	84,762.30	88,798.60	80,726.00	86,780.45	100,100.24
31	0.40	0.38	72,653.40	80,726.00	76,689.70	80,726.00	84,762.30	88,798.60	80,726.00	86,780.45	100,100.24
32	0.40	0.38	72,653.40	80,726.00	76,689.70	80,726.00	84,762.30	88,798.60	80,726.00	86,780.45	100,100.24
33	0.40	0.38	72,653.40	80,726.00	76,689.70	80,726.00	84,762.30	88,798.60	80,726.00	86,780.45	100,100.24
34	0.40	0.38	72,653.40	80,726.00	76,689.70	80,726.00	84,762.30	88,798.60	80,726.00	86,780.45	100,100.24
35	0.40	0.38	72,653.40	80,726.00	76,689.70	80,726.00	84,762.30	88,798.60	80,726.00	86,780.45	100,100.24

Ex. A
pt. 2

Exhibit A, page 2 of 2

ADMINISTRATIVE SALARY SCHEDULE for NON-Certified Staff

For Fiscal Year 2023 - Non Certified

NOTE: Annually change formula in row 13 to match employee longevity as of Aug 1 of new year

	Accts Payable & Billing		Payroll & Benefits		EE change	Food Svc Supervisor	Position Split Transportaion Supervisor	Building & Grounds Superv
Longevity @ Aug 1 2022 ==>	7	8	0	Exec AA/EMIS	7	0	0	
FY-2023 PROPOSED SALARY	\$ 40,819.78	\$ 41,668.22	\$ 36,294.72		\$ 35,516.38	\$ 39,501.00	\$ 57,444.19	
FY22 Salary-->	39,479.10	41,046.14	36,226.95		34,662.37	39,261.60	57,436.80	
CURRENT								
contract days	260.00	260.00	260.00		206.00	210.00	260.00	
days +/-	(2.00)	-	(4.00)		-	-	-	
	(235.68)	-	(471.36)		-	-	-	
	40,819.78	41,668.22	36,294.72		35,516.38	39,501.00	57,444.19	

BASE DAYS	260.00	260.00	260.00		206.00	210.00	260.00
Per diem adjusted annually per prior year							
OAPSE contract	PER DIEM	117.84	117.84	117.84	109.12	150.48	164.88
	BASE \$\$	30,638.40	30,638.40	30,638.40	22,478.72	31,600.80	42,868.80

Longevity	0.02 Longevity Calculated		0.03 Longevity Calculated		1.2	1.2	1.2	1.44	1.25	1.34
	0.00	0.02	0.03	0.06						
0	0.00	0.00	0.00	0.00	36,766.08	36,766.08	36,766.08	32,369.36	39,501.00	57,444.19
1	0.02	0.03	0.03	0.03	37,378.85	37,378.85	37,378.85	32,818.93	40,133.02	58,301.57
2	0.04	0.06	0.06	0.06	37,991.62	37,991.62	37,991.62	33,268.51	40,765.03	59,158.94
3	0.06	0.09	0.09	0.09	38,604.38	38,604.38	38,604.38	33,718.08	41,397.05	60,016.32
4	0.08	0.12	0.12	0.12	39,217.15	39,217.15	39,217.15	34,167.65	42,029.06	60,873.70
5	0.10	0.15	0.15	0.15	39,829.92	39,829.92	39,829.92	34,617.23	42,661.08	61,731.07
6	0.12	0.18	0.18	0.18	40,442.69	40,442.69	40,442.69	35,066.80	43,293.10	62,588.45
7	0.14	0.21	0.21	0.21	41,055.46	41,055.46	41,055.46	35,516.38	43,925.11	63,445.82
8	0.16	0.24	0.24	0.24	41,668.22	41,668.22	41,668.22	35,965.95	44,557.13	64,303.20
9	0.18	0.27	0.27	0.27	42,280.99	42,280.99	42,280.99	36,415.53	45,189.14	65,160.58
10	0.20	0.30	0.30	0.30	42,893.76	42,893.76	42,893.76	36,865.10	45,821.16	66,017.95
11	0.22	0.33	0.33	0.33	43,506.53	43,506.53	43,506.53	37,314.68	46,453.18	66,875.33
12	0.24	0.36	0.36	0.36	44,119.30	44,119.30	44,119.30	37,764.25	47,085.19	67,732.70
13	0.26	0.39	0.39	0.39	44,732.06	44,732.06	44,732.06	38,213.82	47,717.21	68,590.08
14	0.28	0.42	0.42	0.42	45,344.83	45,344.83	45,344.83	38,663.40	48,349.22	69,447.46
15	0.30	0.45	0.45	0.45	45,957.60	45,957.60	45,957.60	39,112.97	48,981.24	70,304.83
16	0.32	0.48	0.48	0.48	46,570.37	46,570.37	46,570.37	39,562.55	49,613.26	71,162.21
17	0.34	0.51	0.51	0.51	47,183.14	47,183.14	47,183.14	40,012.12	50,245.27	72,019.58
18	0.36	0.54	0.54	0.54	47,795.90	47,795.90	47,795.90	40,461.70	50,877.29	72,876.96
19	0.38	0.57	0.57	0.57	48,408.67	48,408.67	48,408.67	40,911.27	51,509.30	73,734.34
20	0.40	0.60	0.60	0.60	49,021.44	49,021.44	49,021.44	41,360.84	52,141.32	74,591.71
21	0.42	0.63	0.63	0.63	49,634.21	49,634.21	49,634.21	41,810.42	52,773.34	75,449.09
22	0.44	0.66	0.66	0.66	50,246.98	50,246.98	50,246.98	42,259.99	53,405.35	76,306.46
23	0.46	0.69	0.69	0.69	50,859.74	50,859.74	50,859.74	42,709.57	54,037.37	77,163.84
24	0.48	0.72	0.72	0.72	51,472.51	51,472.51	51,472.51	43,159.14	54,669.38	78,021.22
25	0.50	0.75	0.75	0.75	52,085.28	52,085.28	52,085.28	43,608.72	55,301.40	78,878.59
26	0.52	0.78	0.78	0.78	52,698.05	52,698.05	52,698.05	44,058.29	55,933.42	79,735.97
27	0.54	0.81	0.81	0.81	53,310.82	53,310.82	53,310.82	44,507.87	56,565.43	80,593.34
28	0.56	0.84	0.84	0.84	53,923.58	53,923.58	53,923.58	44,957.44	57,197.45	81,450.72
29	0.58	0.87	0.87	0.87	54,536.35	54,536.35	54,536.35	45,407.01	57,829.46	82,308.10
30	0.60	0.90	0.90	0.90	55,149.12	55,149.12	55,149.12	45,856.59	58,461.48	83,165.47
31	0.62	0.93	0.93	0.93	55,761.89	55,761.89	55,761.89	46,306.16	59,093.50	84,022.85
32	0.64	0.96	0.96	0.96	56,374.66	56,374.66	56,374.66	46,755.74	59,725.51	84,880.22
33	0.66	0.99	0.99	0.99	56,987.42	56,987.42	56,987.42	47,205.31	60,357.53	85,737.60
34	0.68	1.02	1.02	1.02	57,600.19	57,600.19	57,600.19	47,654.89	60,989.54	86,594.98
35	0.70	1.05	1.05	1.05	58,212.96	58,212.96	58,212.96	48,104.46	61,621.56	87,452.35

EX. B

Lyden Oil Company

Remit To:
3711 LeHarps Road
Youngstown, OH 44515
Phone: (330)792-1100
Fax: (330)792-1462
Quality & Excellence for 100 Years

Account Number: 221198

CHIPPEWA LOCAL SCHOOL DISTRICT
56 N. PORTAGE STREET
DOYLESTOWN, OH 44230

Statement as of 05/31/2022

Inv Date	Due Date	Description	Amount	Paid/Applied	Open
05/05/2022	6/4/2022	Invoice 1858895 (O: 1921827)	2,629.26		2,629.26
05/12/2022	6/11/2022	Invoice 1858884 (O: 1923401)	3,405.13		3,405.13
05/19/2022	6/18/2022	Invoice 1860837 (O: 1925505)	2,880.88		2,880.88
05/20/2022	6/19/2022	Invoice 1860856 (PO: .)	2,446.25		2,446.25
05/26/2022	6/25/2022	Invoice 1862330 (O: 1927668)	2,777.52		2,777.52
		Thank you for your business			
				Balance Due	14,139.04

Remit To:
3711 LeHarps Road
Youngstown, OH 44515

Celebrating a Century of Quality & Excellence: 1919-2019

Please note if we receive your payment on or after the 28th of the month, it may not be reflected on this statement but will appear on the next one.

Winsupply

OF CLEVELAND

4547 HINCKLEY INDUSTRIAL PKWY
 SUITE A
 CLEVELAND, OH 44109-0000
 PHONE (216) 741-1929
 FAX (216) 741-2838

Ex. C
 Pt. 1

Job Name
3 Bay Sinks

Quote No.	Date	Days
0106745	5/09/22	1
Expiration Date		6/08/22
Revised Date		5/09/22
Bid Due Date		5/09/22

Quoted to Customer
S A COMUNALE CO INC PO BOX 150 BARBERTON, OH 44203-0150
Phone (800) 776-7181 Fax (330) 861-0665

Quoted by
Mitchell mrpfeiffer@winsupplyinc.com (216) 741-1929

Customer	Payment Terms	Quoted To	Salesperson	FYB
003209	NET 30 DAYS	Nick Hill	JOHN SIEFERT	S

Line	Qty.	Description	Unit Price	UOM	EXTENDED PRICE
1.0	1	14-3C16X20-2X-18X ELKAY	1834.6600		1834.66
2.0	1	FE-3-1620-18RL-X ADVANCED	1034.1200		1034.12

Tax Area Id	Net Sales	2,868.78
	Freight	.00
	Tax	.00
	Quotation Total	2,868.78

EX. C
pt. 2

S.A. COMUNALE



**Heating*Air Conditioning*Controls* Energy Management * Plumbing * Sprinklers *
Backflows Preventative Maintenance Contracts * Design Build * 24 Hour Service*
Green Buildings**
Alarms*Alarm Monitoring*Water Treatment

"We at Comunale perform all tasks with a sense of urgency and a CAN DO attitude"

May 17, 2022

Hazel Harvey Elementary School
165 Brooklyn Ave.
Doylestown, OH 44230

Attn: Chris Schafrath

S A Comunale Co. Inc. is pleased to present the following quote for your review and approval for replacement and installation of the following:

- New 3-Bay Sink with Double Drain Boards
- New Commercial Basket Strainers and New Plumbing
- New Grease Interceptor
- New Handwash Sink with Splash Guards and New Faucet
- All New Piping to Make Operational
- Permits and Inspections
- Cord Drilling of 2 Holes thru Back Wall
- Re-Use Existing 3 Bay Sink Faucet
- All New Copper Piping, Stainless Steel Supply Lines, and Stops

QUOTE: \$9,785.00

Any unforeseen conditions during the installation and tie in for the above work will be brought to your immediate attention for approval.

Notes:

- ◆ All work performed during our normal business hours, 8:00am – 4:30pm, Monday-Friday.
- ◆ Quote is valid for 30 days from date of issuance.

2900 Newpark Drive · Barberton OH
44203 330-706-3040 · 1-888-857-
2817

EX. C
Pt. 3

S.A.
COMUNALE

 **An EMCOR Company**

To acknowledge your acceptance of this quote, please sign and date below. For your convenience, you may return a signed copy via email at les.beaman@comunale.com.

If you have any questions, or need additional information, please feel free to contact me. Thank you for the opportunity.

Sincerely,
S.A. Comunale Co., Inc.

Les Beaman

Les Beaman
Plumbing Service Manager (330) 608-3599 Cell
(330) 706-3040 ext. 250

Accepted By:

Date: PO#:

EX. C
pt. 4



A-544-912

INSTITUTIONAL GROUP WALL-MOUNT HANDWASH SINK

SUBMITTAL DATA

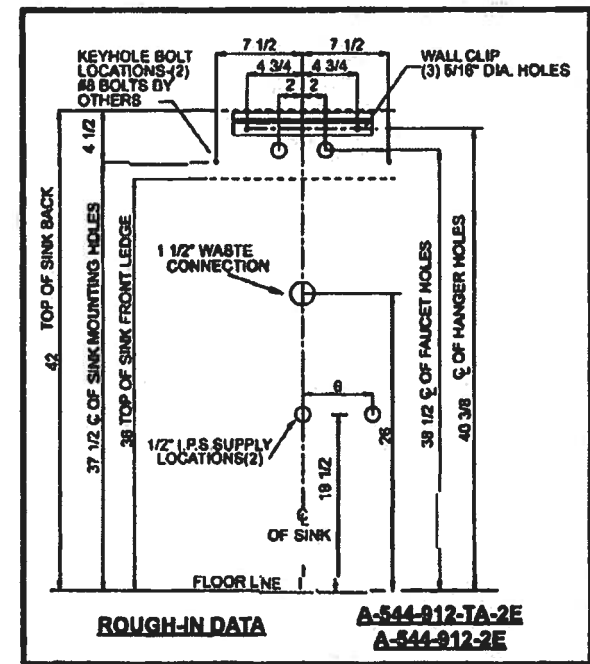
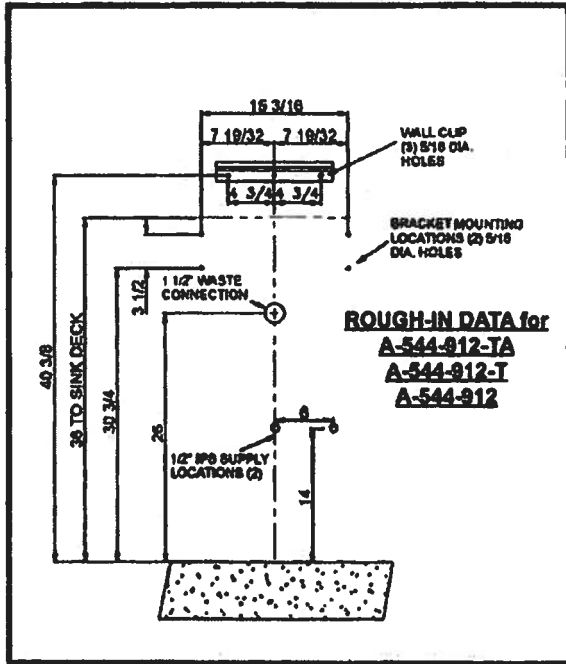
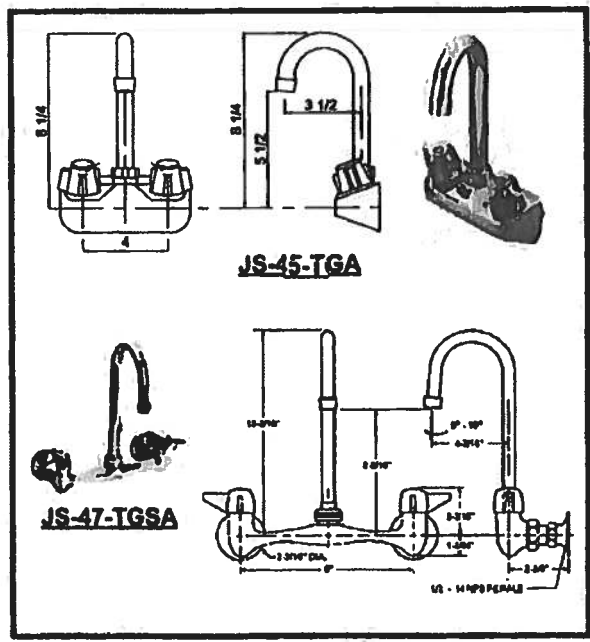
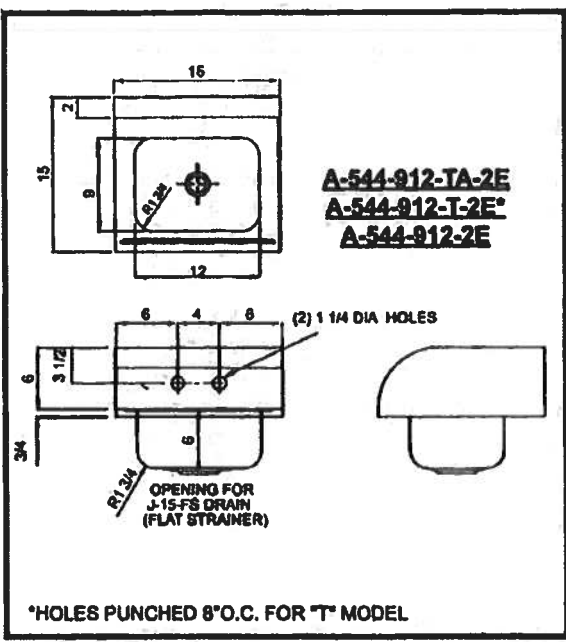

EX. C
pt. 5



A-544-912

INSTITUTIONAL GROUP WALL-MOUNT HANDWASH SINK

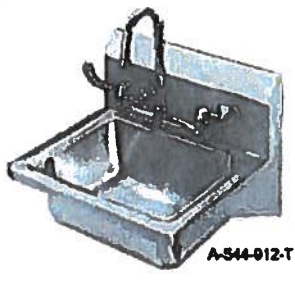

A-544-912-T

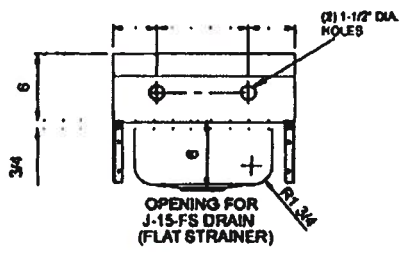
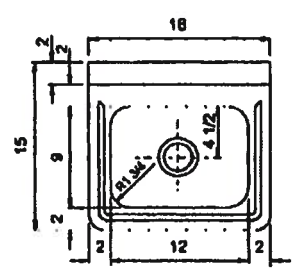

- A-544-912-TA
- A-544-912-T
- A-544-912

APPROVED FOR MANUFACTURING

MODEL NO.: A-544-912-TA-2E QTY: _____

JOB NAME: _____

TAG/ITEM: _____

CUSTOMER: _____

SIGNATURE: _____



SPECIFICATION - HANDWASH SINK NO ENDSPLASHES
Fabricated of 20 gauge type 304 stainless steel. Exposed surfaces polished with a Hand-Blended Just Finish. Integral support bracket at rear. Includes one 14 gauge stainless steel wall clip.

SPECIFICATION - HANDWASH SINK W/ ENDSPLASHES
Fabricated of 20 gauge type 304 stainless steel. Exposed surfaces polished with a Hand-Blended Just Finish. Endsplashes 6" high large radius edge. (Designated by "2E" in suffix) Support integral to endsplashes with keyhole mount. Includes one 14 gauge stainless steel wall clip.

JS-45-TGA gooseneck faucet with aerator. Spout has 3-1/2" reach, and measures 5-1/2" from inlet centerline to top of spout. (4" O.C. supply).

JS-47-TGSA backsplash mounted gooseneck faucet and aerator, with 4-1/16" spout reach. 10-3/16" from inlet centerline to top of spout (8" O.C. supply).

J-15-FS Chrome plated brass drain with flat grid strainer. 1-1/2" O.D. chrome plated tailpiece, 4" long.

JT-150 P-Trap Solid, non adjustable cast brass P-trap with brass slip nut. Hex head cleanout to have neoprene O-ring and top to be flush with inside bottom of J-bend.

The following model does not include faucets and fittings.
A-544-912

	Model No.	Faucet	Drain	Trap
<input type="checkbox"/>	A-544-912-TA	JS-45-TGA	J-15-FS	JTN-150
<input type="checkbox"/>	A-544-912-T	JS-47-TGSA	J-15-FS	JTN-150
<input type="checkbox"/>	A-544-912	NONE	NONE	NONE
<input type="checkbox"/>	A-544-912-TA-2E	JS-45-TGA	J-15-FS	JTN-150
<input type="checkbox"/>	A-544-912-2E	NONE	J-15-FS	JTN-150

JUST MFG. COMPANY CONTINUES TO MAKE QUALITY AND FUNCTIONALITY A MARK OF THE JUST PRODUCT LINE. TO DO SO REQUIRES THAT WE RESERVE THE RIGHT TO CHANGE PRODUCT INFORMATION WITHOUT NOTICE. DIMENSIONS MAY VARY AND ARE SUBJECT TO CHANGE WITHOUT NOTICE. NO RESPONSIBILITY IS ASSUMED FOR USE OF SUPERCEDED OR VOIDED DATA. FOR THE MOST CURRENT AND ACCURATE INFORMATION REGARDING THE COMPLETE LINE OF JUST SINKS, FAUCETS AND DRAINS, CLICK ON THE SPEC LINE DRAWINGS LINK ON OUR WEB SITE AT www.justmfg.com

SUBMITTAL DATA

DIMENSIONS and SPECIFICATIONS

TOL Overall: ± .500" Interior: ± .250"

ALL DIMENSIONS ARE TYPICAL

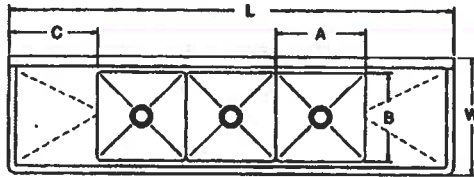

3 COMP - 2 DRBD

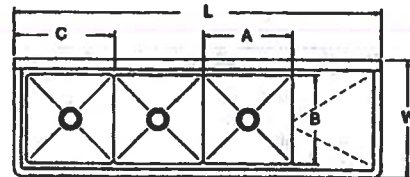

3 COMP - 1 DRBD

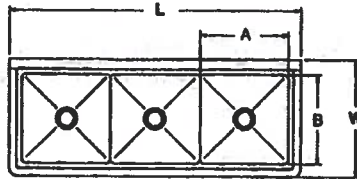

3 COMP

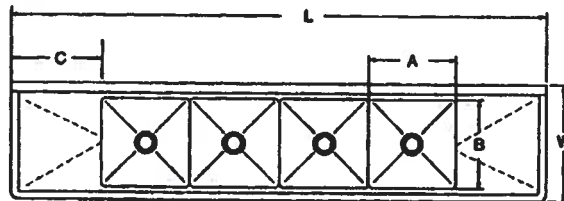

4 COMP - 2 DRBD

ACCESSORIES	Model #	Qty
DRAINS		
FAUCETS		

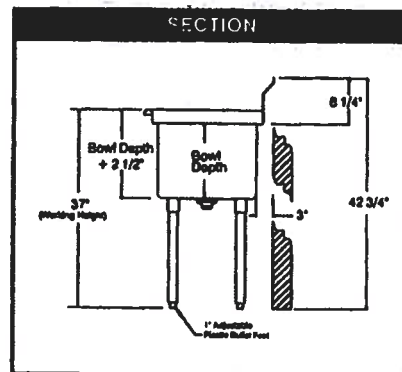
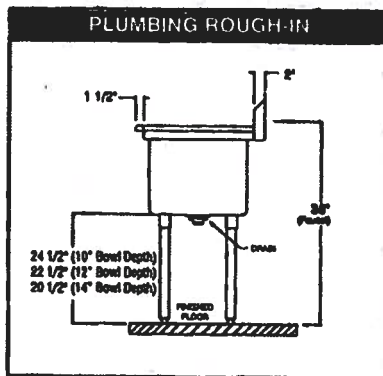



18 GAUGE STAINLESS STEEL
FE SERIES - FABRICATED SINKS NSF
Three Compartments

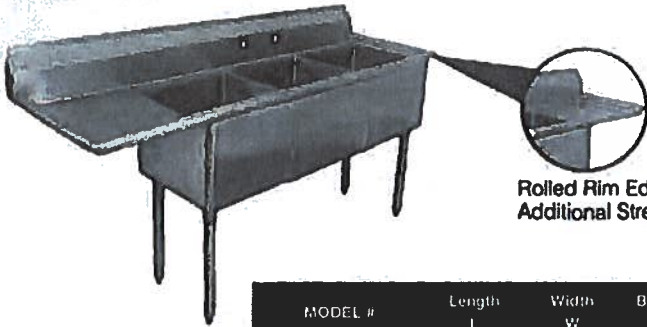

Rolled Rim Edge For Additional Strength

Item #: _____ Qty #: _____
Model #: _____
Project #: _____

MODEL #	Length L	Width W	Bowl Size A & B	Bowl Depth	Drbd. Length Size	# of Drbrds.	Drbd. Location	Wt.	Approx. Cubes
FE-3-1616-X	50"	20 3/4"	16"x15"	12"	N/A	0	None	95 lbs.	25
FE-3-1616-18RorLX	62 1/2"	20 3/4"		12"	15"	1	R or L	105 lbs.	31
FE-3-1616-15RLX	75"	20 3/4"		12"	15"	2	R & L	115 lbs.	31
FE-3-1620-X	53"	25 3/4"	16"x20"	12"	N/A	0	None	88 lbs.	25
FE-3-1620-18RorLX	68 1/2"	25 3/4"		12"	18"	1	R or L	96 lbs.	38
FE-3-1620-18RLX	84"	25 3/4"		12"	18"	2	R & L	105 lbs.	42
FE-3-1614-18RLX	84"	25 3/4"		14"	18"	2	R & L	115 lbs.	42
FE-3-1612-X	59"	23 3/4"	16"x18"	12"	N/A	0	None	90 lbs.	22
FE-3-1612-18RorL-X	74 1/2"	23 3/4"		12"	18"	1	R or L	102 lbs.	29
FE-3-1612-16RLX	90"	23 3/4"		12"	18"	2	R & L	110 lbs.	42
FE-3-1612-24RLX	102"	23 3/4"		12"	24"	2	R & L	149 lbs.	46
FE-3-1614-18RLX	90"	23 3/4"	18"x24"	14"	18"	2	R & L	140 lbs.	42
FE-3-1624-18RLX	90"	29 3/4"		14"	18"	2	R & L	240 lbs.	47
FE-3-1624-24RLX	102"	29 3/4"		14"	24"	2	R & L	250 lbs.	54
FE-3-2424-24RLX*	120"	29 3/4"		14"	24"	2	R & L	340 lbs.	67
SPACE SAVER FE-3-1014-X	35"	19 3/4"	10"x14"	10"	N/A	0	None	85 lbs.	18
FE-3-1014-15RLX	60"	19 3/4"		10"	15"	2	R & L	98 lbs.	22
FE-3-1416-12RLX	66"	21 3/4"	14"x16"	12"	12"	2	R & L	92 lbs.	42



K-700
Removable Side Splashes
Fits Left OR Right Side

FEATURES:

- Backsplash has tile edge for ease of installation.
- Sink bowls are 3/4" coved corner and meet NSF requirements.
- Rolled Rim Edge for additional strength.
- 10"x14 Sink Bowls are 10" deep.
- 14"x16", 15"x15", 16"x20" & 18"x18" Sink Bowls are 12" deep.
- 18"x24" & 24"x24" Sink Bowls are 14" deep.
- 9" Backsplash.

CONSTRUCTION:

- All TIG welded.
- Welded areas blended to match adjacent surfaces and to a satin finish.
- Gussets welded to a die-embossed reinforced plate.

MATERIAL:

- 1 5/8" diameter galvanized legs with 1" adjustable plastic bullet feet.
- Entire unit is 18 gauge 304 stainless steel.
- Gussets - galvanized steel.

MECHANICAL:

- Supply is 1/2" IPS hot & cold.
- Faucet holes on 8" centers.
- Faucets are not included (see accessories).
- Waste drains are 1 1/2" IPS S/S basket type, located in center of sink bowl, and are included.

OPTIONAL:

- FE-SS-12 S/S Leg Upgrade For Sinks w/ 12" Deep Bowls
- FE-SS-14 S/S Leg Upgrade For Sinks w/ 14" Deep Bowls

* Requires Two Faucets



Customer Service Available To Assist You 1-800-645-3166 8:30 am - 7:00 pm E.S.T.

For Orders & Customer Service:
Email: customer@advancetabco.com or Fax: 631-242-6900

For Smart Fabrication™ Quotes:
Email: smartfab@advancetabco.com or Fax: 631-586-2933

EX.C
PT. 8

WATTS®

WD-L Series

Tag: _____

**PDI Certified
Low-Rough-In
Grease Interceptor**

SPECIFICATION: Watts Drainage WD-L Series PDI Certified recessed or floor mounted epoxy coated steel low-rough-in grease interceptor with gasketed epoxy coated steel skid-proof cover secured with hex head center bolt(s), removable baffle assembly, deep seal trap with cleanout, external cast iron flow control fitting, and no hub (standard) connections.

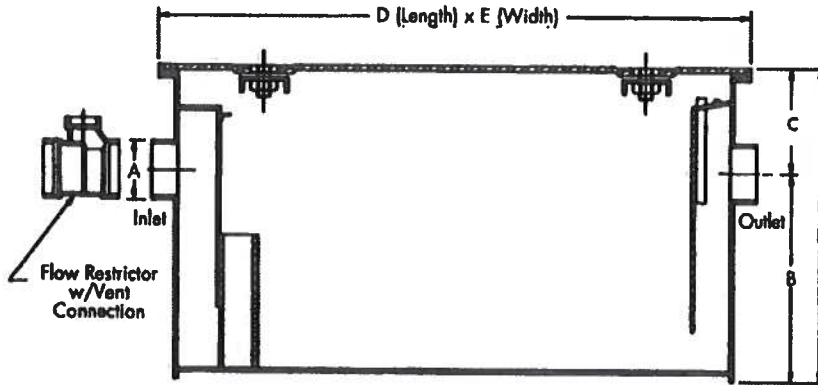

Flow Rate (Select One)		
Suffix	Description	
20	20 GPM	<input type="checkbox"/>
35	35 GPM	<input type="checkbox"/>
50	50 GPM	<input type="checkbox"/>

Options (Select One)		
Suffix	Description	
-B	Sediment Bucket	<input type="checkbox"/>
-E	Extension	<input type="checkbox"/>
-FC	Flange & Clamp Device	<input type="checkbox"/>
-O	Inlet & Outlet other than Standard Size	<input type="checkbox"/>
-SS	Stainless Steel	<input type="checkbox"/>
-THD	Threaded Connections	<input type="checkbox"/>

Interceptor Catalog Number	Flow Rate GPM	Grease Capacity Lbs.	A Inlet & Outlet	B Base To Center	C Top To Center	D Length	E Width	F Height
WD-20L	20	40	3"(76)	7-1/2"(191)	4-1/4"(108)	34-7/8"(886)	22-7/8"(581)	11-3/4"(305)
WD-35L	35	70	4"(102)	7"(178)	4-1/2"(114)	40-7/8"(1038)	32-7/8"(835)	11-7/8"(302)
*WD-50L	50	100	4"(102)	8-1/2"(216)	5-1/2"(140)	55"(1397)	33"(838)	14"(356)

*NOTE: Not PDI Certified

NOTICE

The information contained herein is not intended to replace the full product installation and safety information available or the experience of a trained product installer. You are required to thoroughly read all installation instructions and product safety information before beginning the installation of this product.

Job Name _____

Contractor _____

Job Location _____

Contractor's P.O. No. _____

Engineer _____

Representative _____

Watts product specifications in U.S. customary units and metric are approximate and are provided for reference only. For precise measurements, please contact Watts Technical Service. Watts reserves the right to change or modify product design, construction, specifications, or materials without prior notice and without incurring any obligation to make such changes and modifications on Watts products previously or subsequently sold.

WATTS®

USA: Tel: (800) 338-2581 • Fax: (828) 248-3929 • Watts.com
 Canada: Tel: (905) 332-4090 • Fax: (905) 332-7088 • Watts.ca
 Latin America: Tel: (52) 81-1001-8600 • Fax: (52) 81-8000-7091 • Watts.com

ES-WD-WD-L-SERIES-USA 1713

© 2017 Watts

Ex. E
pt. 1

R.J. Vernak Refrigeration, Inc.
128 E. Smith Road
Medina, Ohio 44256

(330)721-0092

Toll Free: 1-877-721-0092
License # 26229

Fax: (330)721-0692

Date: May 3, 2022

Quote For:

Hazel Harvey Elementary

Attn: Chris

165 Brooklyn Avenue

Doylestown, OH

Contact Phone: 330-212-5457

.....

Std. Nom. Walk-In Freezer: 8'-9 3/4" X 7'-10" X 7'-6" - 4"
extruded polystyrene, stucco embossed galvalume 26 gauge exterior,
stucco embossed galvalume 26 gauge interior, nsf approved.

1 Threshold bar and screws for 34" wide door w/ floor

Floor: 8'-9 3/4" X 7'-10" - 4" extruded insulation, 22 gauge stainless steel
interior, stucco embossed galvalume 26 gauge exterior

U.S. Cooler floors are not designed for the use of Forklifts, Pallet Jacks,
or Hard Wheeled Carts. Damage caused by this usage will void the panel
warranty

Door, 34 In. X 76 In.; low temp inside, with floor, threshold, hinge right 2'
4.5" from back corner on left width wall

******* Includes *******

1 x Vert-Ergo handle

1 x LED light

1 x LED thermometer switch

1 x door closure

2 x adjustable spring-loaded hinges

1 Pressure relief (usc 9644) installed

Refrigeration

1 x Condensing Unit

• Manufacturer: Russell

• Description: Pre-assembled Remote Low Temp R448A Air Cooled

Outdoor Condensing Unit

• Model: RFO230L4SDA

• Dimensions: 39 7/8" X 28 1/4" X 21 1/4"

EX.E
pt. 2

- **Compressor:** 2 hp, Scroll
- **Thermostat:** Electronic Thermostat White Rodgers # 16E09-201
- **Extras:** Liquid line Filter Drier, Sight Glass - Included
- **Electrical:** 208-230/1Phase/60Hz RLA: 12.4 MOPD: 35 MCA: 32
- **Conditions:** BTUH: 6370 Room Temp: -10°F Cond Ambient: 95°F
- **Sizing Room:** 5609 BTUH Needed for 8'-9 3/4" X 7'-10" X 7'-6"
- **Sizing Product:** 518Lbs of Misc Product Entering at 20°F

1 x Evaporator (Unit Cooler)

- **Manufacturer:** Russell
- **Description:** Pre-assembled Electric Defrost Low Profile Coil
- **Model:** RL6E049DDA
- **Dimensions:** 27 1/8" X 15 1/2" X 18 1/8" Fans: 1
- **Extras:** Expansion Valve (ERVE-1/3-ZP), Solenoid Valve (E2S120) - Mounted
- **Electrical:** 208-230/1Phase/60Hz Fan Amps: 0.5 Defrost Amps:

Installation

Installation of all refrigeration piping (Insulated ACR Hard drawn copper tubing)

Installation of freezer panels on level surface

Installation of evaporator coil

Installation of line sets to evaporator coil

Installation of outdoor unit on supplied 6 x 6 treated lumber

Install condensate drain lines to exterior of the building. Heated drain line in freezer space

Install all operators and controls (shipped loose)

Evacuate and charge systems to capacity

90 Day installation warranty

One year parts and labor warranty on refrigeration equipment

All necessary permits and registrations

Note: Electrical by others. Quotation does not include any engineering or stamped drawings that may be required. If needed, these will be an additional charge.

Ex. E
pt. 3

Total Amount of Project: \$28,075.00

Payments to be made as follows: \$18,248.75 down payment, and a balance of \$9,826.25 upon completion. Additional (\$0) sales tax

**Deduct \$2,100.00 if customer disassembles and disposes existing freezer section*

Respectfully submitted by Robert J. Vernak

Date 5/03/2022

ACCEPTANCE OF PROPOSAL

The above prices, specifications and conditions are satisfactory and are hereby accepted. You are authorized to do the work as specified. Payments will be made as outlined above.

Client Signature _____

Please Print Name _____

Date _____

Quotation Valid for 15 Days

Note: Final measurements are necessary prior to manufacturing. Price may vary slightly.

EX. E
Pt. 4

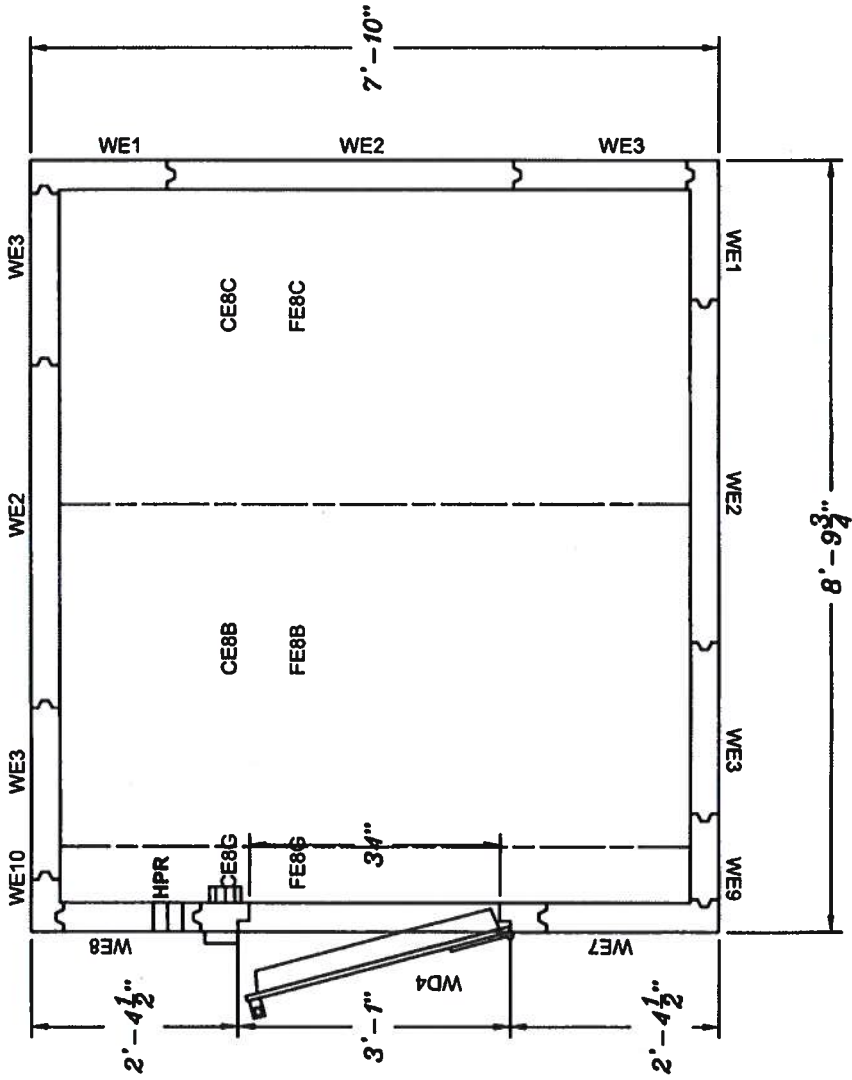
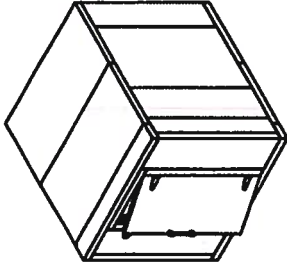

QUOTE DRAWING
Sign below for acceptance
X

By clicking here, you agree to our terms and conditions as outlined on www.uscooler.com/terms. Permit certification subject to U.S. Cooler final approval. A duplicate or unsealed approval of this drawing (SD016A) shall have the same force and effect as a signed original and shall, upon receipt by U.S. Cooler, be binding on both parties.

Materials:
ExtMetal: Galvalume
IntMetal: Galvalume
Foam: Extruded 4in.
Freezer: 8'-9 3/4" x 7'-10" x 7'-6"
Scale: 1/2" = 1'

Legend
Ceiling ---
Floor ---

U.S. COOLER
401 DELAWARE ST. • QUINCY, IL 62301
TEL. 217-228-2421 • 800-821-2883 • FAX. 217-228-2424



CUSTOMER	R.J. Vernak Refrigeration	
JOB#	P.O.# / Job Ref.	/ Chippewa School District
DATE	DRAWN	C.G.S. 3.0
DWG. REF	APY.	583019-0

Refrigeration Specifications			
Qty	Manufacturer	Model	Dimensions DrxWxH
Pre-assembled Remote Low Temp R448A Air Cooled Outdoor Condensing Unit			
1	Russell	RFO230L4SDA	28.25"x39.875"x21.25"
1	Russell	RL6E049DDA	15.5"x21.125"x18.125"

To aid in packing, please indicate with an X the corner where installation will be starting.

Ex. G.
pt. 1

Chippewa Local Schools
Disposal List
Board Meeting June 13, 2022

Type of Device	Serial #	acquisition date	description	NOTES	Location
Desktop Computer	1dqkzk1	8/1/2016	Dell Optiplex 760	Device striped for parts	CIS
Desktop Computer	d7ps011	8/1/2016	Dell Optiplex 760	Device striped for parts	CIS
Desktop Computer	7x5ppj1	8/1/2016	Dell Optiplex 760	Device striped for parts	CIS
Desktop Computer	g8hvsK1	8/1/2016	Dell Optiplex 760	Device striped for parts	CIS
Desktop Computer	dstnpj1	8/1/2016	Dell Optiplex 760	Device striped for parts	CIS
Desktop Computer	4r8s011	8/1/2016	Dell Optiplex 760	Device striped for parts	CIS
Desktop Computer	clqkzk1	8/1/2016	Dell Optiplex 760	Device striped for parts	CIS
Desktop Computer	17vd84j	8/1/2016	Dell Optiplex 760	Device striped for parts	CIS
Desktop Computer	7x8llk1	8/1/2016	Dell Optiplex 760	Device striped for parts	CIS
Desktop Computer	cpgvsk1	8/1/2016	Dell Optiplex 760	Device striped for parts	CIS
Desktop Computer	j18fpn1	8/1/2016	Dell Optiplex 760	Device striped for parts	CIS
Desktop Computer	5fbs3l1	8/1/2016	Dell Optiplex 760	Device striped for parts	CIS
Desktop Computer	gi1h3l1	8/1/2016	Dell Optiplex 760	Device striped for parts	CIS
Desktop Computer	34ztk1	8/1/2016	Dell Optiplex 760	Device striped for parts	CIS
Desktop Computer	b81npj1	8/1/2016	Dell Optiplex 760	Device striped for parts	CIS
Desktop Computer	bvsm4m1	9/3/2017	Dell Optiplex 780	Device striped for parts	CIS
Desktop Computer	9wd7km1	9/3/2017	Dell Optiplex 780	Device striped for parts	CIS
Desktop Computer	4hlfnn1	8/2016	Dell Optiplex 760	Device striped for parts	CIS
Desktop Computer	6wczn1	8/2016	Dell Optiplex 760	Device striped for parts	CIS
Desktop Computer	43zbd01	8/2016	Dell Optiplex 760	Device striped for parts	CIS
Printer	98116wv	8/2010	Lexmark cv540n	No longer works	HH
Printer	Cnh8c3jgr	3/2011	Hp laser jet pro cm 1415frnw	No longer works	HH
TV	C503835255	3/2005	Sharp tube tv	No longer using	HH
TV	616213	4/1998	Sharp tube tv	No longer using	HH
DVD / VHS	Hrxc18bu	6/2005	Jvc dvd/vhs player	No longer using	HH
DVD / VHS	902lnar409920	2/2009	Zenith dvd/vhs player	No longer using	HH
Printer	995d217	4/2009	Lexmark e120	No longer works	HH
Laminator	Th1703800058	4/2015	Gbc ultima 65	No longer works	HH
DVD / VHS	910inj507836	10/2009	JVC dvd/vhs player	No Longer Using	HH
DVD / VHS	139A1260	8/2004	JVC dvd/vhs player	No longer works	HH

EX. G
pt. 2

Line Printer	B48B097427	Pre-2000	Tally T6101, Model 648	Obsolete	Board Office
Napkin Dispenser	63-33-001	Jan-15	TORK Xpressnap	Obsolete	Board Office
Basketball Backboards				Obsolete	CIS
Various Pots/Pans				Not functional	HH
Mixer				Broke/Obsolete	HH
Student desks/Chairs					HH

Ex. H

Purchase Order Information - 22000966 - Chippewa Local SD - Live

Approval Status Add Item Requisition Detail Delete Line Item Tax Rate

Date: 06/03/2022 Period: 11/22

Header Line Item (1 of 1)

RO# 72000966

Detail Information

Purchase Order: 22000966 Shipping Charge Continuous
 Requisition: 22001280 X-Posted
 Commodity: Approval Status
 Status: Date Received
 Extended Asset: Received: 0.00

105,542.00

45,000.00

Bus Grant

60,542.00

Per m. Improv.

Stock Number

ricing

Measure: Extended Amount: 105,542.00 Total Tax: 0.00
 Quantity: 1.00 Discount Percent: 0.0000 Total Price: 105,542.00
 Unit Price: 105,542.0000 Trade/Discount: 0.00 Distribution Method: A - Amount
 Shipping: 0.00

BUDGET UNIT	Account	Account	Percentage	Amount
4999022285000000	660		0.43	45,000.00
0030000285000000	660		0.57	60,542.00